

BY8301-16P voice module manual

1、 Overview

BY8301-16P Shenzhen Balway Electronic Technology Co., Ltd. is a self-developed a new type of high-quality MP3 compact module, using BY8301-SSOP24 MP3 main chip, support MP3, WAV format double decoding. SPI-FLASH module built as a storage medium, with a Microc USB interface, no PC software, you can connect your computer free replacement FLASH audio content via data cable. And withinSet 3W amplifier, can directly drive 3W speakers, easier to use.

2、 Product Features

- supports MP3, WAV audio formats with high quality, beautiful sound.
- 24-bit DAC output, support dynamic range 90dB, SNR support 85dB.
- Micro USB interface to update the voice files, without having to install the PC software. Support XP and WIN7 system.
- supports 21 voice segment one trigger playback, 3 IO port select eight kinds of hardware trigger wider application.
- support asynchronous serial UART Control: Support play, pause, and down song, volume addition and subtraction, playing selections, advertising spots and so on.
- built-in volume, track, EQ down memory function.
- maximum support 16M byte capacity SPI FLASH. For example GD25Q16 [2M bytes], GD25Q128 [16M bytes]
- comes with 3W amplifier, external speakers directly to complete the play; customers can also add a single, dual-channel amplifier.
- standard 2.54mm pin spacing DIP16 package, compact appearance.

3、 Technical Specifications

Name	Parameter
MP3, WAV file format	supports sample rates 8 ~ 48K, the bit rate of 8 ~ 320Kbps audio files
USB 2.0 interface	standard (Micro USB interface to connect a computer to download the voice can also be read U disk contents)
UART interface	standard serial port, 3.3V TTL level, baud rate 9600
Input voltage	3.6V-5V (recommended value 4.2V)
Quiescent current	15MA (entire module)
Power amplifier	connected 3W / 4Ω or 2W / 8Ω speaker
Size	21mm * 18mm
Operating temperature	-40 °C ~ 70 °C
Humidity	5% ~ 95%

4、 Module pin map

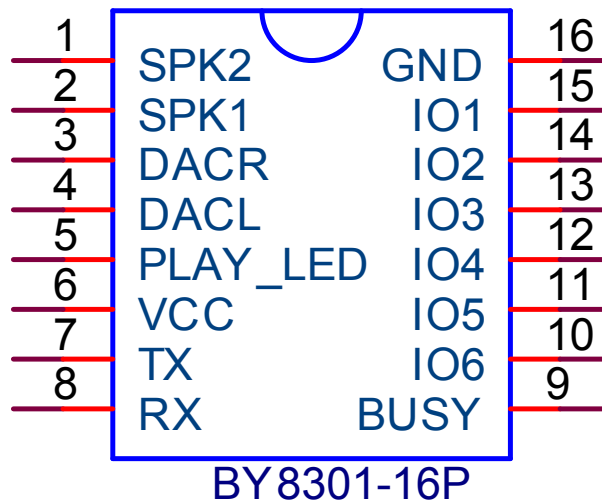

Pin No.	Pin Name	Function Description	Remarks
1	SPK2	external mono speaker	then 3W / 4Ω or 2W / 8Ω, passive speaker
2	SPK1	external mono speaker	then 3W / 4Ω or 2W / 8Ω, passive speaker
3	DACR	DAC right channel output	external amplifier, headphones
4	DACL	DAC left channel output	external amplifier, headphones
5	PLAY_LED	play indicator	standby light is playing flashes
6	VCC	the positive power supply	3.6-5V
7	TX	UART asynchronous serial data output	3.3V TTL level
8	RX	UART asynchronous serial data input	3.3V TTL level
9	BUSY	when playing high output, low stop	busy signal
10	IO6	trigger input port 6	grounding trigger
11	IO5	trigger input port 5	grounding trigger
12	IO4	trigger input port 4	grounding trigger
13	IO3	trigger input port 3	grounding trigger
14	IO2	trigger input port 2	grounding trigger
15	IO1	trigger input port 1	grounding trigger
16	GND	negative power	systematically

5、Module package size

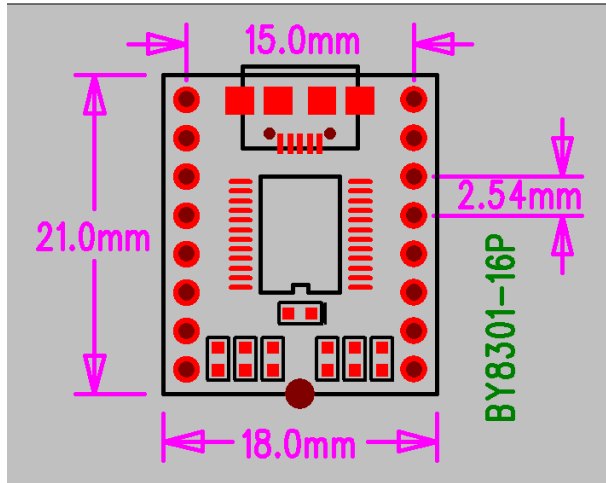

6、 IO port button trigger Description

This module has six Trigger IO ports, supports up to 21 segments one trigger button to play. By three IO ports through 3.3K resistor to ground or not connected to eight kinds of control mode selection for a variety of applications.

Resistor settings control mode in front of the module, marked with ABC character defaults module 010, the customer can go back voluntarily modify:

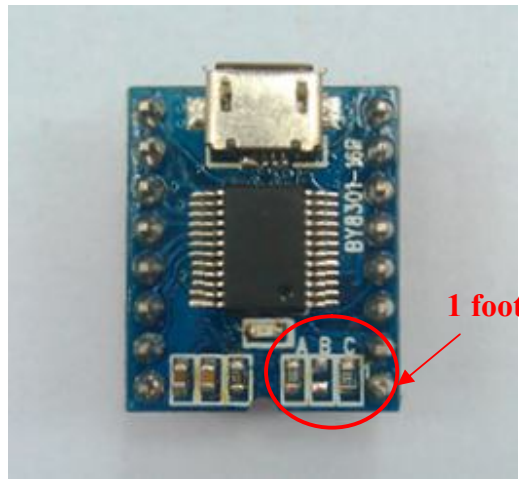

Section 21 key one application:

IO1	One play, song 1	IO2* IO3	One play, song 12
IO2	One play, song 2	IO2* IO4	One play, song 13
IO3	One play, song 3	IO2* IO5	One play, song 14
IO4	One play, song 4	IO2* IO6	One play, song 15
IO5	One play, song 5	IO3* IO4	One play, song 16
IO6	One play, song 6	IO3* IO5	One play, song 17
IO1* IO2	One play, song 7	IO3* IO6	One play, song 18
IO1* IO3	One play, song 8	IO4* IO5	One play, song 19
IO1* IO4	One play, song 9	IO4* IO6	One play, song 20
IO1* IO5	One play, song 10	IO5* IO6	One play, song 21
IO1* IO6	One play, song 11		

3 IO port selection control mode application (3.3K ground zero, to float a), the default value 010:

IOA	IOB	IOC	One key trigger function (the button is pressed both effective without release)
-----	-----	-----	---

0	0	0	Key grounded, triggering stop playing again, half-way trigger is invalid; long time exceed the current song, loop, finished playing again in the middle lift stop	
0	0	1	Key grounding, ON / OFF function. Click the play, during playback, the trigger again to stop, and then trigger the stop state is played from the beginning, once you finish playing the current song stops	
0	1	0	Ground button, click on the ring, ring in the process, the press will be interrupted, and then re-start play, finished play once then stop	
0	1	1	Ground button, click on the ring, then the process can not be interrupted in the ring until the ring have been exhausted, then finished only effective response	
1	0	0	Hold trigger level, has been pressing the play button again, lift the stop button halfway (not for serial control in this mode)	
1	0	1	Trigger level to maintain circulation, has been pressing the button loop, lift the stop button halfway (not for serial control in this mode)	
1	1	0	Standard MP3 mode	
			IO1	Play / Pause / long press 2 seconds to stop the current song
			IO2	Under a (short press) / Volume + (long press)
			IO3	Under a (short press) / Volume + (long press)
			IO4	Volume +
			IO6	Hold trigger level, has been pressing the play button, lift the stop button (this function is not down song)
1	1	1	Application-specific features	
			IO1	Key grounded, triggering stop playing again, half-way trigger is invalid; long time exceed the current song, loop, finished playing again in the middle lift stop
			IO2	Press a short / long press the volume +
			IO3	On a short press / long press volume -
			IO4	Volume +
			IO6	PLAY button, press play, during playback, then will break, and then went heavy head start playing, once you finish playing stops

7、Applications

- industrial control areas: industrial control equipment;
- Intelligent Transportation Equipment: toll stations, car parks, car voice prompts;
- advertising industry: advertising language broadcast;
- access control, time and attendance: The door has been opened, such as voice prompts;
- security industry: the human body sensors prompt, safe and voice prompts, Tips;
- advanced toys: Swing machine, hit the crash, game consoles;
- Medical Electronics: Equipment voice prompts;
- Communication Education: Educational equipment, electronic communications;

8、Serial Control Protocol

BY8301 built-in standard asynchronous serial UART interface, are 3.3V TTL level interface. Can be converted to RS232 level through the MAX3232 chip. Communication data format is: Start bit: 1; data bits: 8; Parity: None; Stop Bits: 1. Using the computer serial debugging assistant, you need to set the correct serial port parameters, settings shown:



Protocol command format:

Start code	length	opcodes	parameters	check code	end code
0X7E	see below	see below	see below	see below	0XEF

Note: all the data as a hexadecimal number."Length" refers to the length of the + operator code + Parameter Length + checksum,"Checksum" refers to the value of the length of the operation code, parameters negated, customers can get through checksum calculator.

For example, playing instructions for 7E 03 01 02 EF checksum 02 is obtained by:

First, open the calculator programmer mode selection;

Then select the hex, double word;

Finally, click to calculate $3 \text{ Xor } 1 = 2$



Command sent successfully returned OK, stop the song finishes playing return STOP.

8.1 Instruction List

Communications Control Instructions (Another company a BY8001-16P TF card card voice module)

Detailed CMD	Corresponding function	Parameters
0x01	Play	no
0x02	Pause	no
0x03	Under	no
0x04	On	no
0x05	Volume increase	no
0x06	Volume reduction	no
0x07	Standby / work	no, enters standby current 10MA
0x09	Reset, no	no
0x0A	Fast-forward,	no, FLASH no function
0x0B	Rewind	no, FLASH no function
0x0E	Stop	no
0x31	Set the volume	0-30 adjustable (off memory)
0x32	Setting EQ	0-5 (NO\POP\ROCK\JAZZ\CLASSIC\BASS) (off memory)
0x33	Setting cycle mode	0-4 (All/Folder/single player/random/broadcast again)
0x34	Folder switching	0 (a folder), 1 (next folder)
0x35	Device switching	0 (U), 2 (FLASH)
0x41	Choose to play tracks	1-255 first (off memory)
0x42	Specify a folder track is playing	high eight for the folder number (00-99), the low eight song name (001-255), FLASH no function
0x43	Spots feature	1-65536, FLASH no function
0x44	Spots designated folder inside the songs	high eight for the folder number (00-99), the low eight song name (001-255), FLASH no function
	Combination play	Combination play different tracks will be sent continuously aired stop, maximum support 10 segments

Communications query

Detailed CMD	Corresponding function	Parameter
0x 10	Query playing status	0 (stop) 1 (Play) 2 (Pause) 3 (fast forward) 4 (rewind)
0x 11	Query volume.	0-30 (off memory)
0x 12	Query the current EQ	0-5 (NO\POP\ROCK\JAZZ\CLASSIC\BASS) (off memory)
0x 13	Query the current play mode	0-4 (All/Folder/single player/random/broadcast again)
0x 14	Query version	1.0
0x 16	Query U disk total file totals	1-65535
0x 17	The total number of files query FLASH	1-255
0x 18	Query the current playback device	0:USB 2:SPI
0x 1A	Current track queries U disk	1-65536
0x 1B	The current track queries FLASH	1-255
0x 1C	Query the currently playing song time	Anti-back time (in seconds)

0x 1D	Query the current total time playing songs	Anti-back time (in seconds)
0x 1E	Query the currently playing song	In return the song name (SPI internal songs can not be anti-back)
0x 1F	Query the current playback folder within the total number of	0-65536(SPI internal songs can not be anti-back)

8.2 Control instructions detailed instructions

8.2.1 Play

Startcode	Length	Opcode	Checksum	End code
7E	03	01	02	EF

Send the command to Play music, pause or stop state to start playback.

8.2.2 Pause

Startcode	Length	Opcode	Checksum	End code
7E	03	02	01	EF

Send the command to pause playback music.

8.2.3 Next song

Startcode	Length	Opcode	Checksum	End code
7E	03	03	00	EF

This command can trigger the next song Play music while playing the last piece of music, send the command to trigger the first song Play music.

8.2.4 On song

Startcode	Length	Opcode	Checksum	End code
7E	03	04	07	EF

This command can trigger the next song Play music while playing the first song to music, send the command can be triggered to play the last piece of music.

8.2.5 Volume +

Startcode	Length	Opcode	Checksum	End code
7E	03	05	06	EF

Chip has 30 adjustable volume, send a command, a volume increase.

8.2.6 Volume -

Startcode	Length	Opcode	Checksum	End code
7E	03	06	05	EF

Chip has 30 adjustable volume, send a command, a volume reduction.

8.2.7 Standby / normal operation

Startcode	Length	Opcode	Checksum	End code
7E	03	07	04	EF

Send this instruction chip into standby status at work, in the standby state needs to send commands to wake the chip to work properly again.

8.2.8 Reset

Startcode	Length	Opcode	Checksum	End code
7E	03	09	0A	EF

Send this instruction resets the chip.

8.2.9 Fast Forward

Startcode	Length	Opcode	Checksum	End code
7E	03	0A	09	EF

Sends a command to fast forward the music for some time.

Note: FALSH not have this feature.

8.2.9 Rewind

Startcode	Length	Opcode	Checksum	End code
7E	03	0B	08	EF

Sends a command to rewind the music for some time.

Note: FALSH not have this feature.

8.2.10 Stop

Startcode	Length	Opcode	Checksum	End code
7E	03	0E	0D	EF

Send this instruction in music Play or pause state can stop the music.

8.2.11 Set Volume

Startcode	Length	Opcode	Volume Level	Checksum	End code
7E	04	31	19	2C	EF

0-30 adjustable volume, real-time modification of the directive can adjust the volume, the volume can be powered down memory paradigm hair

Send volume level is 25.

8.2.12 Setting EQ

Startcode	Length	Opcode	Parameters	Checksum	End code
7E	04	32	00	36	EF

Send this instruction can change EQ.

8.2.13 Setting cycle mode

Startcode	Length	Opcode	Parameters	Checksum	End code
7E	04	33	02	35	EF

Send this instruction cycle mode can be set, for example to set single cycle mode.

8.2.14 Folder Switching

Startcode	Length	Opcode	Parameters	Checksum	End code
7E	04	34	01	31	EF

Send the command to switch folders Play, sending one to the next folder, and 0 on a folder.

Note: FALSH not have this feature.

8.2.15 Switching equipment

Startcode	Length	Opcode	Parameters	Checksum	End code
7E	04	35	01	30	EF

When the system has multiple devices, you can send the command to select the device to be read, for example select TF card player.

8.2.16 Select a track Play

Startcode	Length	Opcode	Tracks high	Tracks low	Checksum	End code
7E	05	41	00	01	45	EF

Send this command to specify the corresponding storage track is playing, play the first example of a song.

Note: Tracks for 1-65536

8.2.17 Specify the folder track playback

Startcode	Length	Opcode	Tracks high	Tracks low	Checksum	End code
7E	05	42	00	02	45	EF

Sowing the corresponding tracks corresponding instruction can specify a folder within a folder 8 high number, low 8 to the song title.Examples for the specified folder 00 in the first two Play.

Note: If you want to use this feature, the folder must be named 00-99, songs must be named 001-255, No Mistakes will not be played. FALSH not have this feature.

8.2.18 Spots feature

Startcode	Length	Opcode	Tracks high	Tracks low	Checksum	End code
7E	05	43	00	03	45	EF

When receiving the instruction of this article, we pause a track, and then to implement this directive specified Play tracks, When finished playing, then Play the original Pause tracks.

Note: FALSH not have this feature.

8.2.19 Spots designated folder songs

Startcode	Length	Opcode	Tracks high	Tracks low	Checksum	End code
7E	05	44	01	06	46	EF

When receiving the instruction of this article, we pause a track, and then to implement this directive specified in the file.Corresponding track is playing, when finished playing, then Play the original Pause tracks. High eight for the folder number, the lower 8 bitsThe song title.

Note: If you want to use this feature, the folder must be named 00-99, songs must be named 001-255, NoMistakes will not be played. FALSH not have this feature.

8.2.20 Combination Play

Continuous transmission:

7E 05 41 00 01 45 EF 7E 05 41 00 02 46 EF 7E 05 41 00 03 47 EF 7E 05 41 00 40 EF

Play 1,2,3,4 song aired stop, up to 10 continuous playback.

8.3 Query command Description

After sending the query command returns the corresponding value, not described in detail.

9、 Application Circuit

Note that all the main chip IO port voltage is 3.3V, note that the voltage matches other microcontrollers connected!

9.1 . 21 Road buttons control application circuit K1-K21 corresponding voice segment 1-21

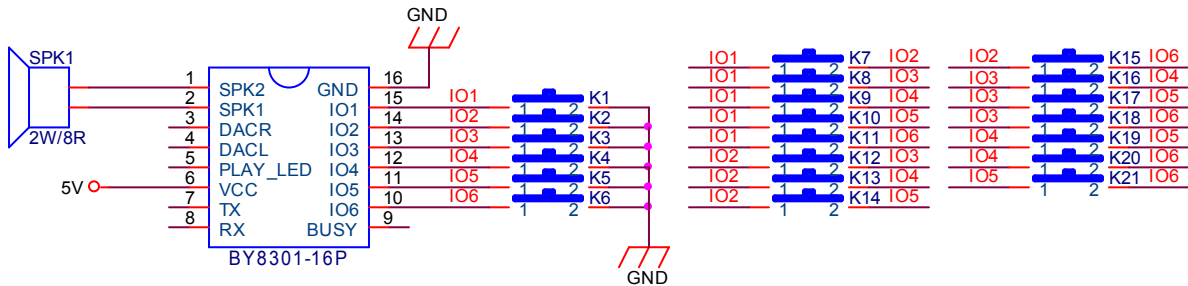

21-way switch button is equivalent to the amount of control.

9.2 . Microcontroller serial control application circuit

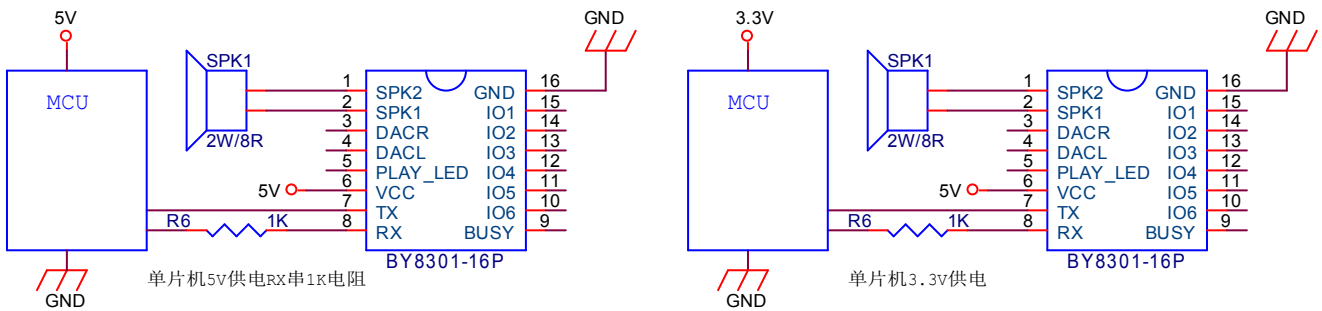

The above is a standard UART asynchronous serial connectivity applications, this application is quite flexible, including play, pause, up and down the song, volume addition and subtraction, Play selections, advertising spots and so on. Available microcontroller, computer serial port control 485 can also be controlled by TTL to RS485 adapter plate.

9.3 . MCU IO port directly connected to the control application circuit

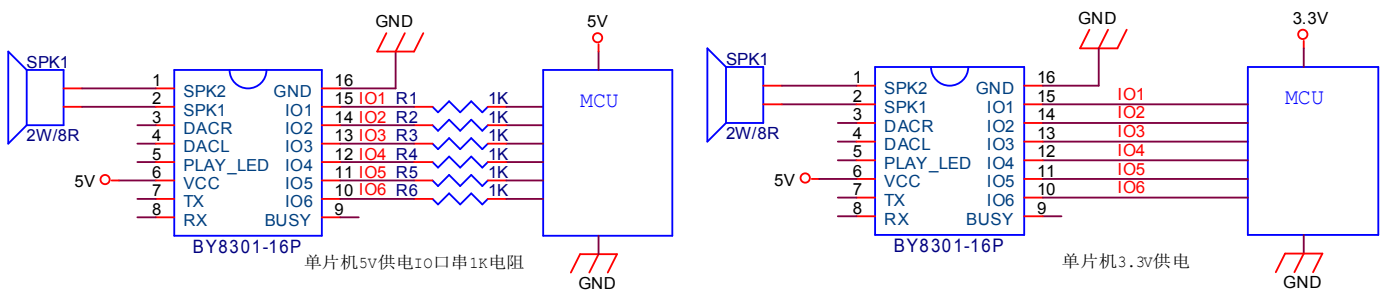

By the microcontroller through a low pulse signal (equivalent to pressing the lift button) can trigger IO1-IO6, achieve one Play six segments voice, and above 3IO selectable control modes.

9.4 . For some customers may use the trigger level to play, you can use the relay control can also be used optocoupler control, providing connection diagram below:

Relay

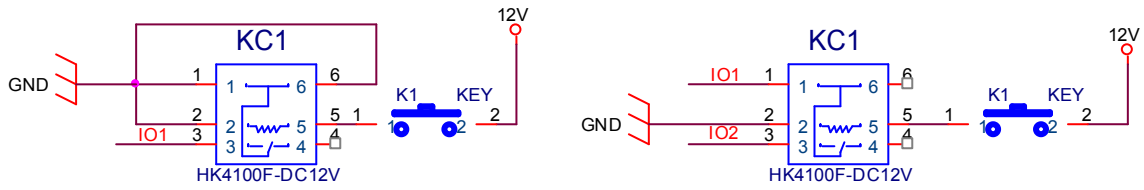

Left IO port down play, the figure for the Play in the first paragraph; right is IO combination play, the relay is energized IO1, IO2 short-circuit Play in paragraph 6.

Optocoupler

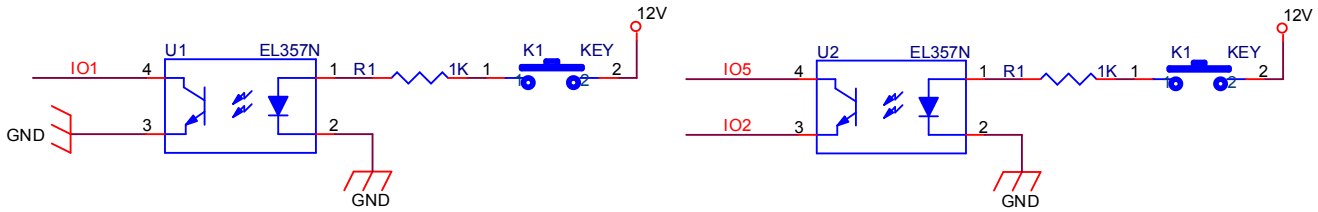

Left IO port down play, the figure for the Play in the first paragraph; right is IO combination play, the rules of connections is the low number of connections IO port optocoupler 3 feet, 4 feet high number of connections, the figure for the first 14 Play segment.

Given above is 12V trigger level can also be converted to a single-chip high-low trigger.

9.5 . External amplifier application circuit

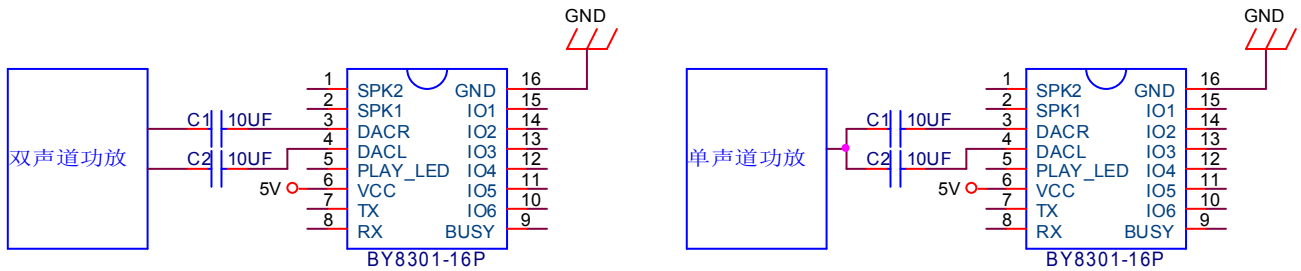

The module power is mainly the customer can own an external amplifier.

10、 Copy MP3 to store FLASH

Our modules can use the MICRO USB phone lines directly on the computer to update voice, convenient and flexible. ComputerThe first time you plug in the product, installation requires some time, please be patient, wait for the next time very quicklyNo need to plug in the power supply direct phone line. The computer will pop up the following screen, and then the computer 360 software, or kill,Virus software off, or after the following window pops up choose USB plug allows the program to run:



The computer will pop up the following screen:

有可移动存储的设备 (3)



10.1. Open the "CD Drive", the computer will enter the following interface. Then open the application, it will pop up "10.2" in the interface.



10.2. Select "Load Zone 1" folder, as shown above and click "Load File" will pop up a window to load voice, As shown below:

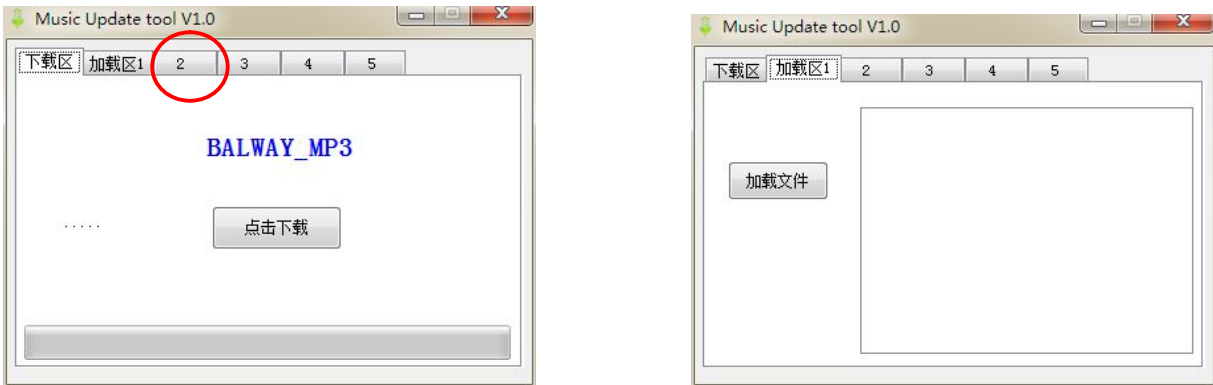

10.3. At this point you need to load the selected voice, you need to put on a one-time multi-stage election finished, the entire sequence can be selected into a loading area (area 2-5 are reserved function without load), and then click "Open" to add the software in the. Voice document proposes naming 0001XXX.mp3,0002XXX.mp3

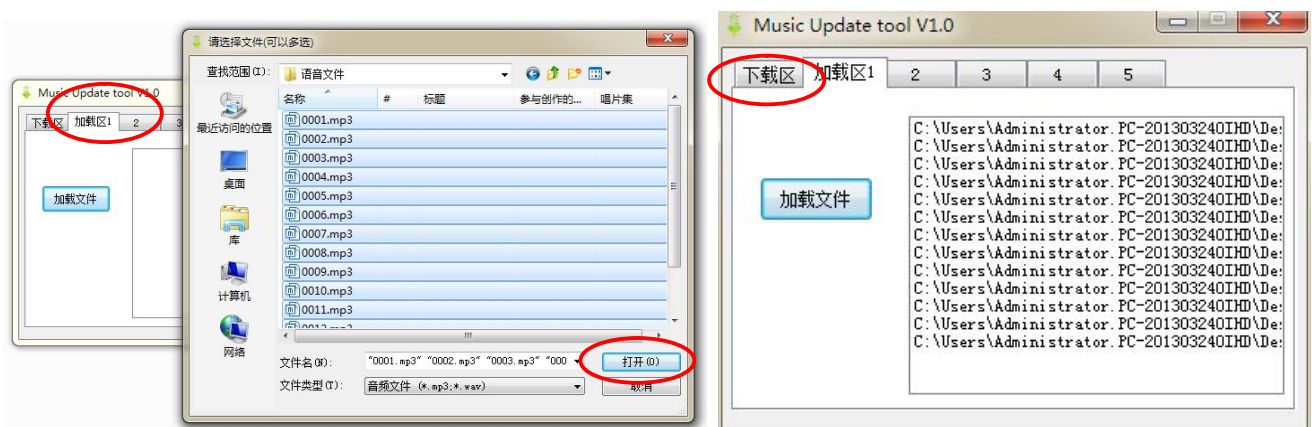

10.4. Finally, back to the "Downloads" screen, click on the "Download" button, the following screen will appear. From

left to right, three windows, a window displays the last "check success", on behalf of the update is complete, close the window directly to unplug the USB cable on it.



11、 Manual version

Version	Date	Description
V1.0	2014-3-20	The initial version
V1.1	2014-6-28	Perfect serial control instructions
V1.2	2014-10-9	Add some application circuit

Shenzhen Electronic Balway Technology Co., Ltd. is a set of voice solutions, voice semi-finished speech development, production and service in one of technology-based enterprises, the main research has been focused on speech technology, voice chip solution, MP3 module, voice prompts board, voice finished products such as software and hardware design, development and customization. And to undertake electronic product development and small batch production, post-production and mature manner using OEM supplier, the business scope of automotive electronics, security, home security, communications, home appliances, medical equipment, industrial automation and control, education, equipment, toys and gifts consumer products and other fields.

Shenzhen Best Electronic Technology specializes in the development, design, production and sales of voice products. The main circuit board for research and development of products BY series of voice, voice chip solution, MP3 voice module, greeting module, TF card MP3 module, USB MP3 module, 12V playback boards, high-power multi-channel playback control panels, door voice Reminder, advertising tips, a truck speed limiter, as well as customers with special needs to develop a voice product development programs, and implement the program, to complete product development, testing, until the actual application of the guidance products and other services. After years of development, the company has formed a complete system of technology development process, can quickly develop customer demand for products, uphold the high degree of enthusiasm and sophisticated technology, has always been to serve our customers for the purpose, committed to market strategy. For the needs of the market, in the company's meticulous efforts of all staff, the products will be comprehensive, thorough, to meet customer demand,

improve efficiency, and cost-effective. We adhere to the people-oriented service attitude, to reach a two-way communication with customers, providing high-quality products and excellent service of the people.

Shenzhen Electronic Technology Co., Ltd. is currently the sales and service strategy to enhance customer service quality, to help develop the most competitive end products, we uphold a positive innovation, courage, customer satisfaction, teamwork, the market has been gradually from China extended to all regions of the globe. The company's competitive advantages include the following four points:

(A) professional and innovative research and development capabilities, high-quality research and development and engineering and technical teams;

(B) the strong long-term relationship market, the price has the absolute advantage;

(C) the full range of technical support and improve the marketing system;

(D) stable product delivery and quality assurance.

Shenzhen Balway Electronic Technology Co., Ltd.

Website: www.balway.com

E-mail: balway@163.com

TEL: 0755-33142633

**Rm.303, Huafujin Mansion, No.81 building, Baishilong,
New Yixiu village, Minzhi Street, Bao'an District, Shenzhen, 518131**